



# Tubular Heaters

## Straight and Formed



U.L. AND C-UL Recognized-E177353

### Features

- The Hotwatt Tubular Heater has built-in resistance to shock, vibration, corrosion, and temperature extremes.
- The heater is swaged, reducing the diameter of the metal sheath and compacting the insulation. This insures rapid heat transfer and holds the coil in position for forming.
- Many formations are available.
- Long, trouble free service.
- Made in U.S.A.

### Construction

**1** Steel, stainless steel, copper, or Incoloy sheathed elements.

**2** Element wire situated in proximity to outside surface for maximum heat transfer and minimum internal temperature while preserving good dielectric qualities.

**3** Pure magnesium oxide compressed to an optimum density for best heat transfer and electrical insulation at elevated temperatures.

**4** Weld connection.

**5** Cold pin.

**6** Insulator.

**7** Standard post terminal.

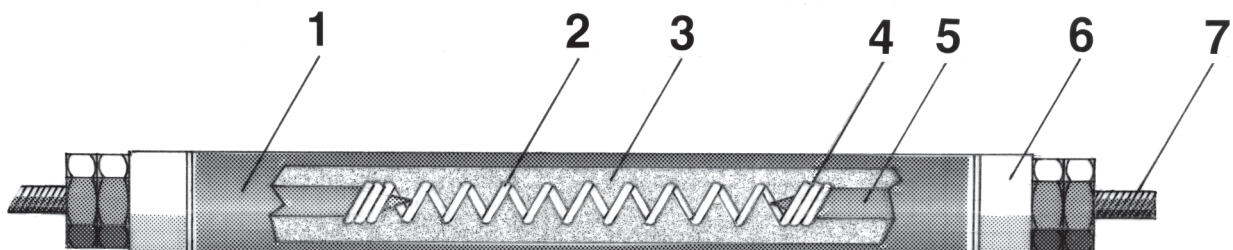

TUBULAR



# Tubular Heaters

## Straight and Formed

### Standard Sizes and Materials

The sheath materials available are stainless steel, steel, copper, and incoloy. Standard diameters are: .260", .315", .375", .440" and .490". Diameter tolerance is  $\pm .010$ ".

Sheath Material	Max. Temp. Allowed on Sheath	Max. Length of Sheath	Max. Cold Lengths
Steel	750°F	252"	96"
Copper	350°F	252"	96"
St. Steel	1200°F	324"	96"
Incoloy	1600°F	324"	96"

### Sheath Materials and Watt Densities

Application	Approx. Operating Temp.	Rec. Sheath Material	Watts/sq. in. Of Element Surface
Clamped to Surfaces	up to 300°F	Steel	30
	500°F	Steel	20
	800°F	Incoloy	15
	1000°F	Incoloy	10
	1200°F	Incoloy	7
	1400°F	Incoloy	2.5
Still Air (Sheath Temp.)	800°F	Incoloy	7
	1000°F	Incoloy	11
	1200°F	Incoloy	14
	1400°F	Incoloy	30
Clamped into Machined Grooves	500°F	Steel	25
	800°F	St. Steel	15
	900°F	Incoloy	15

### Formula for Determination of Unit Wattage

**Unit Wattage** = Diameter x 3.142 x Heated Length x Allowable watts/sq. in.

### Electrical Tolerances and Limits

Sheath Diameter	.260"	.315"	.375"	.440"	.490"
Min. OHMS/in.	.15	.05	.05	.05	.05
Max. OHMS/in.	80	50	50	50	50
Max. Voltage	250	300	480	600	600
Max. Amperes	20	30	40	40	40

Wattage tolerance is +5%, -10% at rated volts.

### Standard Length Tolerances

Sheath Length	Length	Heated Length
Up to 20"	$\pm \frac{1}{6}$ "	$\pm 2\%$
20" to 100"	$\pm \frac{1}{8}$ "	$\pm 2\%$
100" to 200"	$\pm \frac{1}{4}$ "	$\pm 2\%$

### Cold Ends

When not specified, cold ends will be the minimum length as shown in the table below. Longer cold lengths may be specified. Optional cold ends of unequal lengths are available.

Sheath Length	Minimum Cold Ends
Up to 20"	1"
20" to 100"	1½"
100" to 200"	4"

### Mounting Fittings

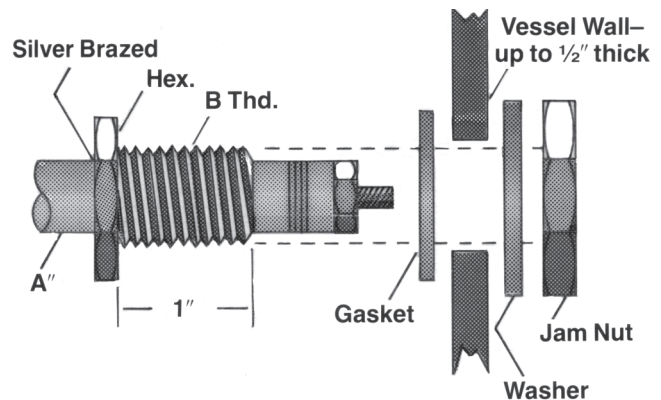

Fittings are available with light jam nuts (plated steel), plain washers (plated steel), and/or copper gaskets.

Brass bushings are used with copper and steel sheaths. Silver brazed stainless steel bushings are used with stainless steel and Incoloy sheaths. Welded stainless steel bushings are available at additional cost.

Catalog Number	Sheath Diameter A"	Thread Size B"
EF-12	.260"	½"-20
EF-13	.315"	½"-20
EF-16	.375"	¾"-18
EF-17	.440"	¾"-16
EF-17	.490"	¾"-16

### Forming

If you plan to do the bending required, observe the minimum bend limits in the table, and do not plan any bend within 1" of a cold end junction.

Annealing for bending must be specified.

If Hotwatt is to do the bending, submit a sketch showing clearly the form the bent unit is to take.

#### Minimum Bend Radius

Diameter	.260"	.315"	.375"	.440"	.490"
Formed By Factory	¼"	⅝"	¾"	⅞"	⅞"
Formed By Customer	¾"	1"	1¼"	1½"	1½"



# Tubular Heaters

## Straight and Formed

### Optional Terminations

#### SF3S: Post

Post terminations will be supplied unless otherwise specified.

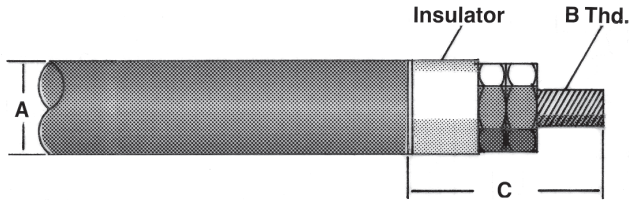

A	B	C	Max. Amps.
.260"	6-32	5/8"	20
.315"	6-32	5/8"	20
.375"	8-32	3/4"	30
.375"	10-32	1"	40
.440"	8-32	3/4"	30
.440"	10-32	1"	40
.490"	10-32	1"	40

#### SF3P: Pin

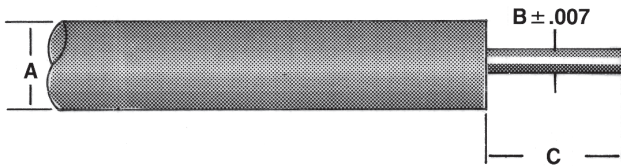

A	B	C	Max. Amps.
.260"	.091"	5/8"	20
.315"	.135"	5/8"	20
.375"	.156"	3/4"	40
.440"	.156"	3/4"	40
.490"	.156"	3/4"	40

#### SF3T: Tab

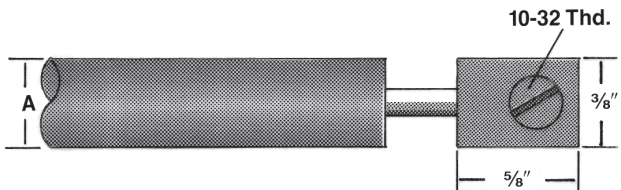

A	Max. Amps.
.260"	20
.315"	30
.375"	30
.440"	30
.490"	30

#### SF2A: Lead Wire

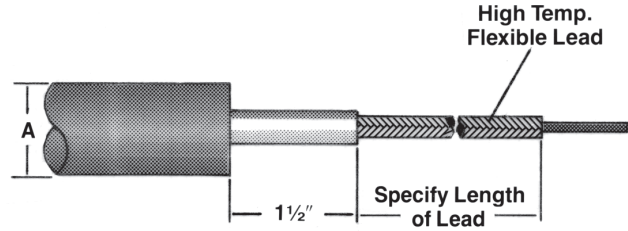

A	Max. Amps.
.260"	21
.315"	28
.375"	28
.440"	28
.490"	28

#### SF23: Hermetic Seal

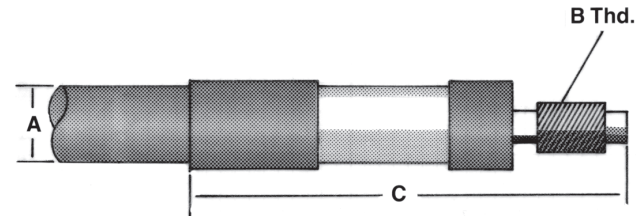

A	B	C	Max. Amps.
.260"	8-32	1 1/8"	20
.315"	10-32	1 1/4"	30
.375"	10-32	1 1/2"	30
.440"	1/4-28	2 1/8"	40
.490"	1/4-28	2 1/2"	40

#### SF11: Quick Connect

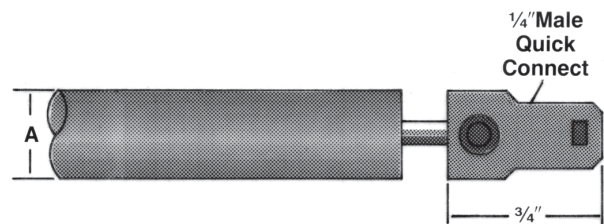

A	Max. Amps.
.260"	20
.315"	30
.375"	30
.440"	30
.490"	30



# Tubular Heaters

## Straight and Formed

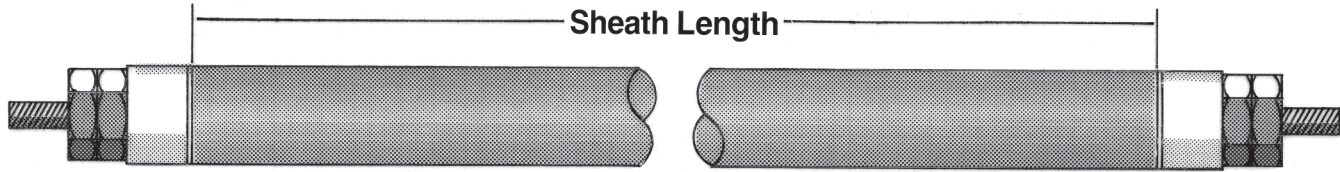

<b>Diameter:</b>	<b>.260: Incoloy</b>	<b>.315: Incoloy</b>	<b>.375: Incoloy</b>
<b>Maximum Amperage:</b>	<b>20</b>	<b>30</b>	<b>40</b>

Sheath Length	Cat. No.	Max. Watts at 240V	Cat. No.	Max. Watts at 240V	Cat. No.	Max. Watts at 480V
20"	TA26-20	555	TA31-20	675	TA37-20	800
40"	TA26-40	1210	TA31-40	1465	TA37-40	1745
60"	TA26-60	1860	TA31-60	2255	TA37-60	2685
80"	TA26-80	2515	TA31-80	3050	TA37-80	3630
100"	TA26-100	3170	TA31-100	3840	TA37-100	4570
120"	TA26-120	3825	TA31-120	4630	TA37-120	5515
140"	TA26-140	4475	TA31-140	5425	TA37-140	6455
160"	TA26-160	4640	TA31-160	6215	TA37-160	7395
180"	TA26-180	4640	TA31-180	7010	TA37-180	8340
200"	TA26-200	4640	TA31-200	7005	TA37-200	9285
220"	TA26-220	4640	TA31-220	7005	TA37-220	10225
240"	TA26-240	4640	TA31-240	7005	TA37-240	11170

<b>Diameter:</b>	<b>.440: Incoloy</b>	<b>.490: Incoloy</b>	<b>.260: St. Steel</b>
<b>Maximum Amperage:</b>	<b>40</b>	<b>50</b>	<b>20</b>

Sheath Length	Cat. No.	Max. Watts at 480V	Cat. No.	Max. Watts at 480V	Cat. No.	Max. Watts at 240V
20"	TA44-20	960	TA49-20	1055	TT26-20	420
40"	TA44-40	2090	TA49-40	2300	TT26-40	910
60"	TA44-60	3225	TA49-60	3545	TT26-60	1395
80"	TA44-80	4355	TA49-80	4790	TT26-80	1885
100"	TA44-100	5485	TA49-100	6035	TT26-100	2375
120"	TA44-120	6615	TA49-120	7280	TT26-120	2865
140"	TA44-140	7745	TA49-140	8520	TT26-140	3355
160"	TA44-160	8880	TA49-160	9765	TT26-160	3845
180"	TA44-180	10010	TA49-180	11010	TT26-180	4340
200"	TA44-200	11140	TA49-200	12255	TT26-200	4705
220"	TA44-220	12270	TA49-220	13495	TT26-220	4705
240"	TA44-240	13400	TA49-240	14740	TT26-240	4705

<b>Diameter:</b>	<b>.315: St. Steel</b>	<b>.375: St. Steel</b>	<b>.440: St. Steel</b>
<b>Maximum Amperage:</b>	<b>30</b>	<b>40</b>	<b>40</b>

Sheath Length	Cat. No.	Max. Watts at 240V	Cat. No.	Max. Watts at 240V	Cat. No.	Max. Watts at 480V
20"	TT31-20	505	TT37-20	600	TT44-20	720
40"	TT31-40	1095	TT37-40	1305	TT44-40	1570
60"	TT31-60	1690	TT37-60	2015	TT44-60	2415
80"	TT31-80	2285	TT37-80	2720	TT44-80	3265
100"	TT31-100	2880	TT37-100	3425	TT44-100	4115
120"	TT31-120	3475	TT37-120	4135	TT44-120	4960
140"	TT31-140	4065	TT37-140	4840	TT44-140	5810
160"	TT31-160	4660	TT37-160	5550	TT44-160	6660
180"	TT31-180	5255	TT37-180	6255	TT44-180	7505
200"	TT31-200	5850	TT37-200	6965	TT44-200	8355
220"	TT31-220	6440	TT37-220	7670	TT44-220	9205
240"	TT31-240	7035	TT37-240	8375	TT44-240	10050

TUBULAR



# Tubular Heaters

## Straight and Formed

Diameter:		.260: Steel		.315: Steel		.440: Steel	
Maximum Amperage:		20		30		40	
Sheath Length	Cat. No.	Max. Watts at 240V	Cat. No.	Max. Watts at 240V	Cat. No.	Max. Watts at 240V	Cat. No.
20"	TS26-20	280	TS31-20	335	TS44-20	480	
40"	TS26-40	605	TS31-40	730	TS44-40	1045	
60"	TS26-60	930	TS31-60	1130	TS44-60	1610	
80"	TS26-80	1260	TS31-80	1525	TS44-80	2175	
100"	TS26-100	1585	TS31-100	1920	TS44-100	2745	
120"	TS26-120	1910	TS31-120	2315	TS44-120	3310	
140"	TS26-140	2240	TS31-140	2710	TS44-140	3875	
160"	TS26-160	2565	TS31-160	3105	TS44-160	4440	
180"	TS26-180	2890	TS31-180	3505	TS44-180	5005	
200"	TS26-200	3220	TS31-200	3900	TS44-200	5570	
220"	TS26-220	3545	TS31-220	4295	TS44-220	6135	
240"	TS26-240	3870	TS31-240	4690	TS44-240	6700	

Diameter:		.315: Copper		.440: Copper	
Maximum Amperage:		30		40	
Sheath Length	Cat. No.	Max. Watts at 240V	Cat. No.	Max. Watts at 600V	
20"	TC31-20	1345	TC44-20	1925	
40"	TC31-40	2930	TC44-40	4185	
60"	TC31-60	4515	TC44-60	6445	
80"	TC31-80	6095	TC44-80	8710	
100"	TC31-100	6890	TC44-100	10970	
120"	TC31-120	6890	TC44-120	13230	
140"	TC31-140	6890	TC44-140	15495	
160"	TC31-160	6890	TC44-160	17755	
180"	TC31-180	6890	TC44-180	18885	
200"	TC31-200	6890	TC44-200	18885	
220"	TC31-220	6890	TC44-220	18885	
240"	TC31-240	6890	TC44-240	18885	

### Wattage

Wattages as shown in the above tables are based on sheath material or voltage/amperage limitations. For allowable wattage for your application, refer to Sheath Material/Watt Density chart on page 77.

### How To Order

**Specify:** catalog number, wattage, voltage, termination and other optimal features. If forming is required, include a dimensional sketch and reference formation number, if applicable, as shown on pages 83 and 84.

**Example:** TA31-40/1000W240V/SF3S